

Bicycle and Pedestrian Paths/LRT Crossings

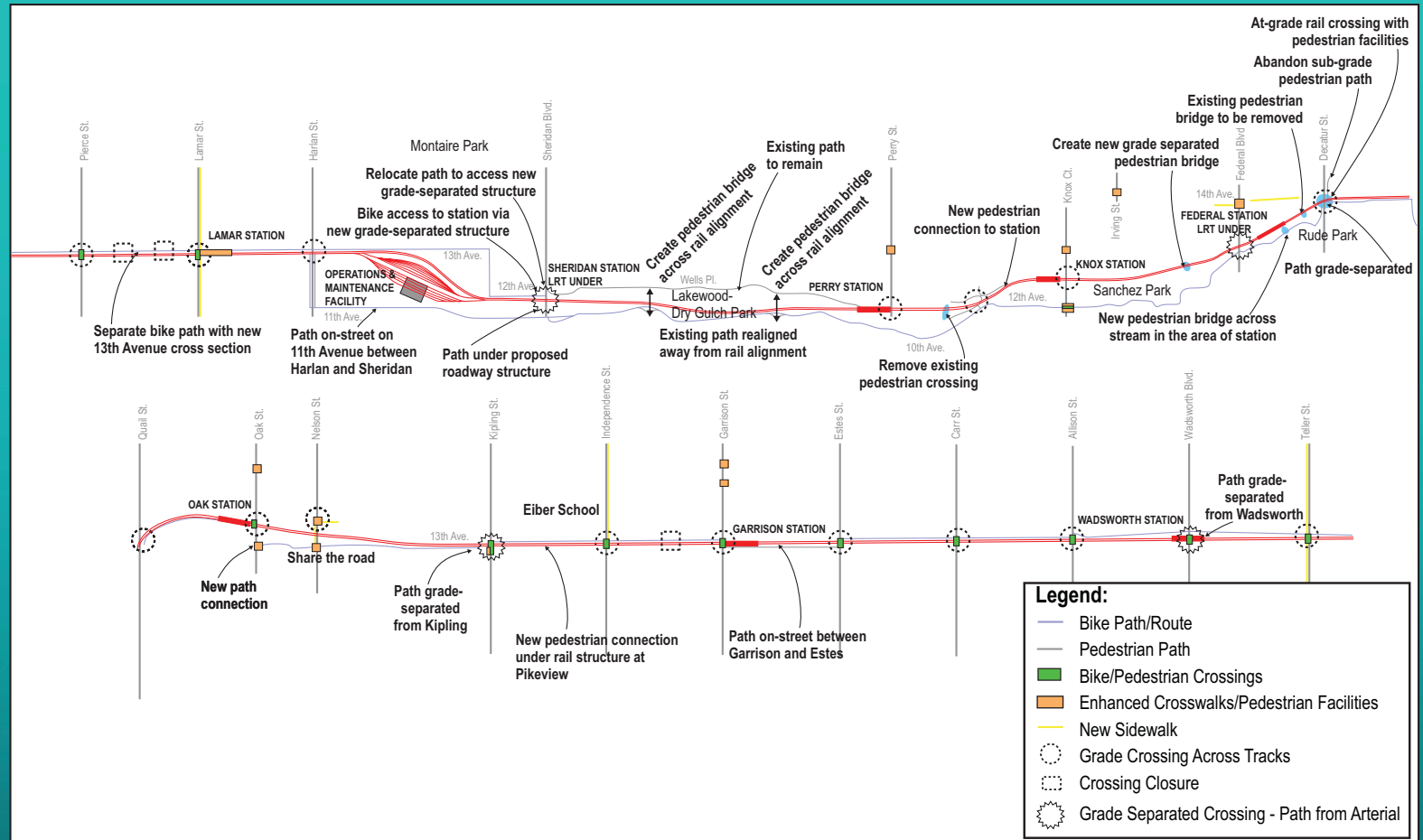

Bike Storage Capacity

	Lockers	Racks
Auraria West	4	10
Federal/Decatur	4	10
Knox	4	10
Perry	4	10
Sheridan	4	10
Lamar	4	10
Wadsworth	4	10
Garrison	4	10
Oak	4	10
Denver Federal Center	4	10
Red Rocks	4	10
Jeffco	4	10

j:\Facilities\02-3344 FasTracks West Corridor\3344.0- Drawings\Current\WCSTDTJ004.dwg
 Jul 17, 2007 - 12:55pm

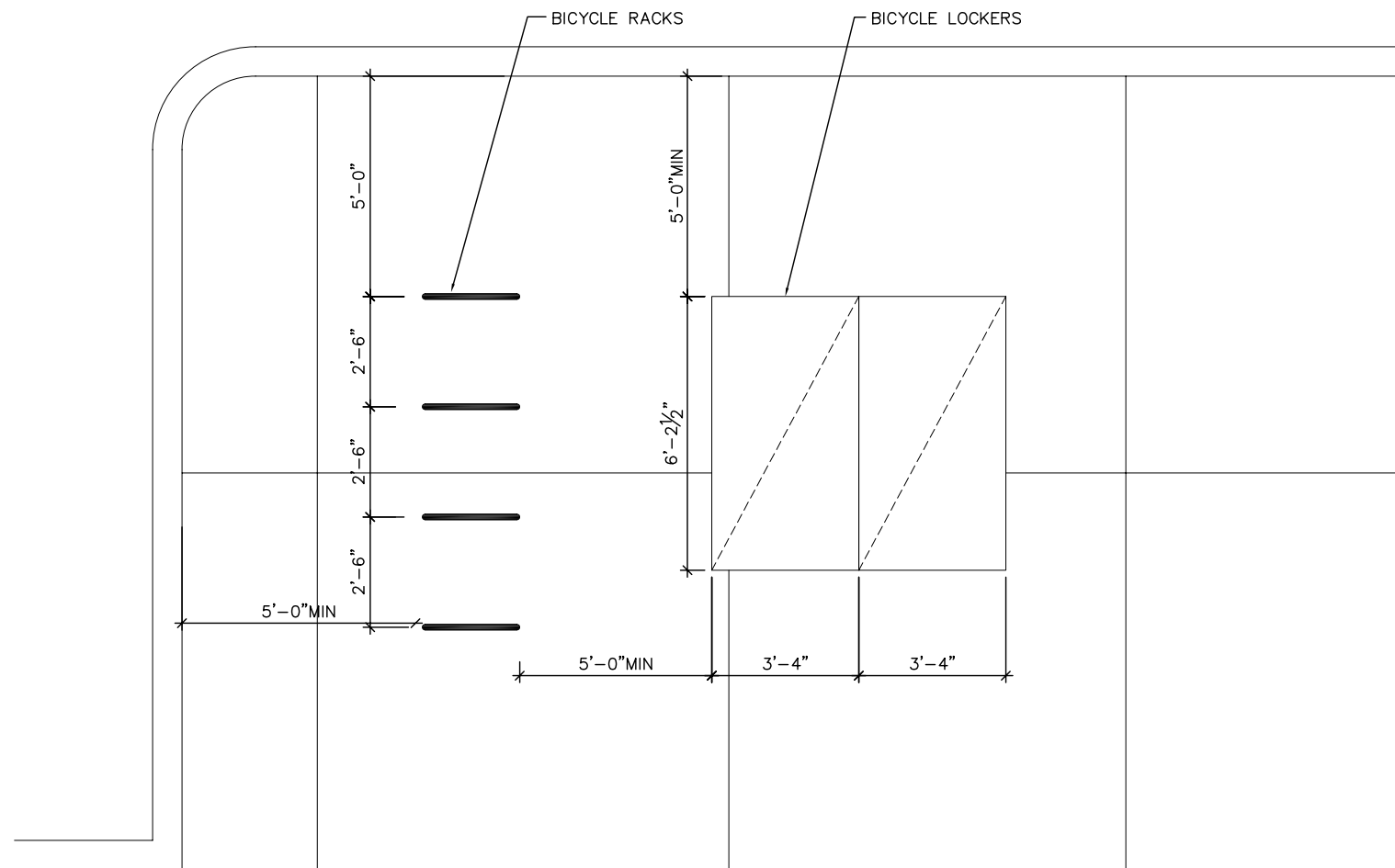

4 TYPICAL BICYCLE RACK & LOCKER LAYOUT
 SCALE: 1"=2'-0"

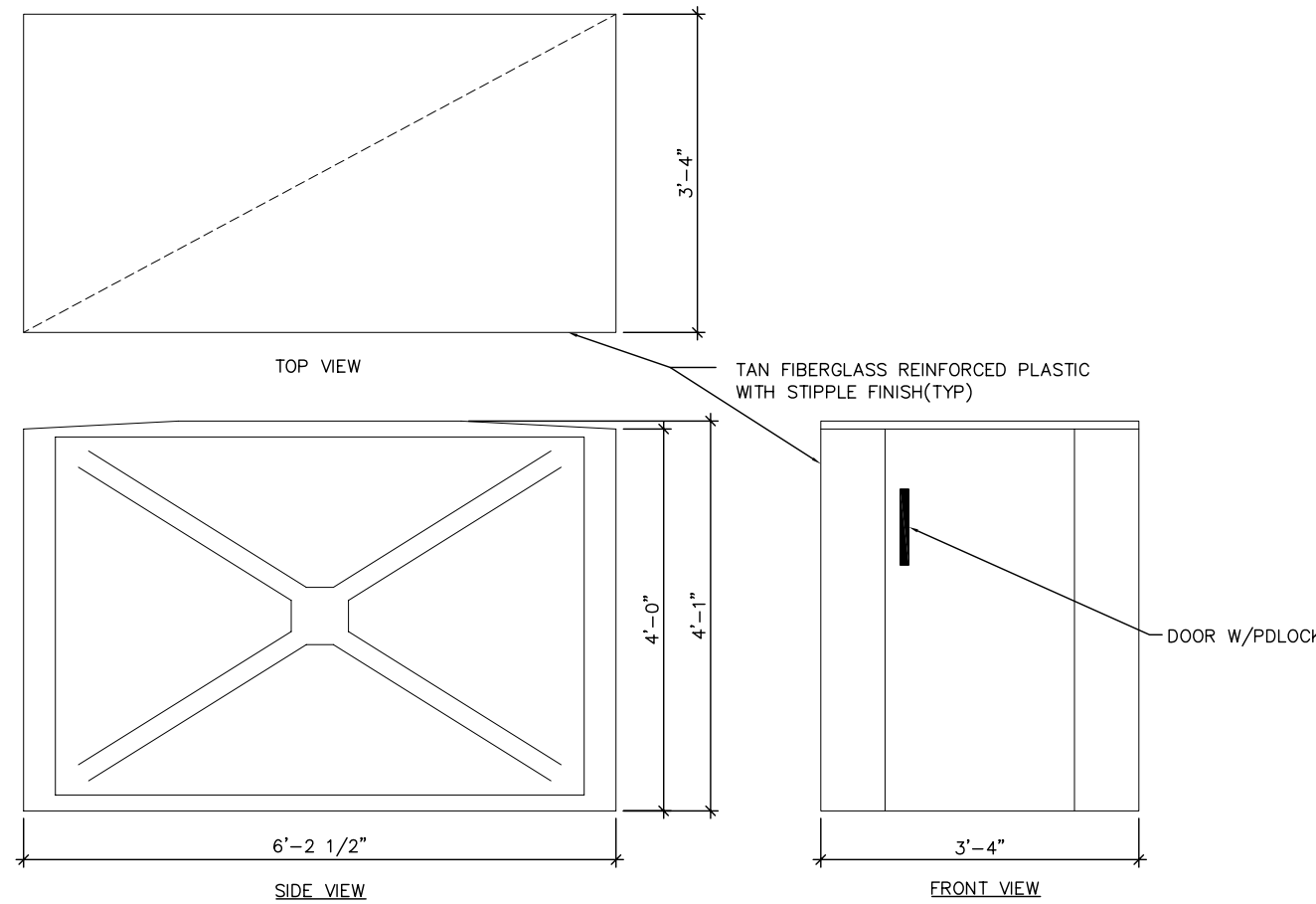

3 BICYCLE LOCKERS AMERICAN BICYCLE SECURITY MODEL 352
 SCALE: 1"=1'-0" W/PADLOCK HANDLE PN #010

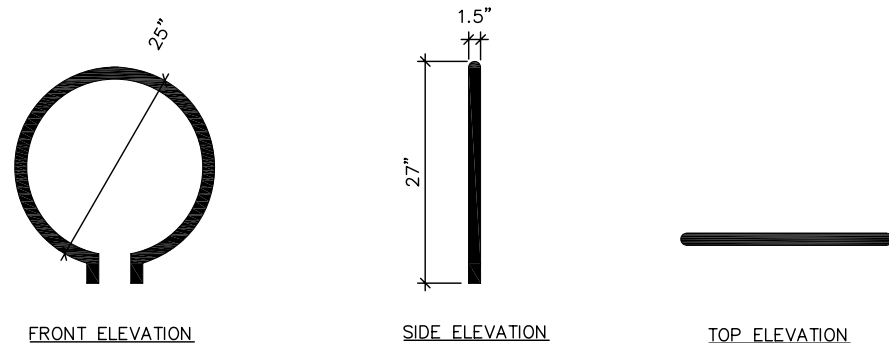

2 BICYCLE RACK DETAIL
 SCALE: 1"=1'-0"

FURNISHINGS TYPICAL TO ALL STATIONS SYSTEM WIDE
 FINAL QUANTITIES FOR INDIVIDUAL STATIONS VARY BASED ON AREA AVAILABLE AT TRANSITION PLAZAS

	ITEM	QTY.	REMARKS
[BR]	BIKE RACK	4	LANDSCAPE FORMS RING BIKE RACK (1 1/2" x 25" x 27") SURFACE MOUNT
[BB]	BIKE BOX	2	REFER TO RTD STANDARD
[TR]	TRASH RECEPTALS	4	LANDSCAPE FORM-LAKESIDE LITTER RECEPTACLE, TOP OPENING, CUSTOM DESIGN (21" X 36") SURFACE MOUNT
[BNCH]	BENCHES	4	LANDSCAPE FORM-LAKESIDE, BACKED BENCH WITH INTERMEDIATE ARM, 24" X 36" X 67"), SURFACE MOUNT
[NM]	NEWSPAPER/MAGAZINE ENCLOSURES	2	PROVIDED BY OTHERS
[EPH]	EMERGENCY PHONE	2	REFER TO ELECTRICAL DRAWINGS
[TVM]	TICKET VENDING MACHINE	2	REFER TO ELECTRICAL DRAWINGS
[V]	VALIDATOR	2	REFER TO ELECTRICAL DRAWINGS

1 SITE FURNISHING SCHEDULE
 SCALE:

NO.	REVISIONS	BY	DATE	DESIGNED BY: SB	DATE: 3-21-07	CHECKED BY: PZ	DATE: 7-12-07	RTD CONTRACT NO. 15DH007
				DRAWN BY: CV	DATE: 3-21-07	APPROVED BY:	DATE:	DATE:
				DAVID EVANS AND ASSOCIATES INC. 1331 17th Street, Suite 900 Denver, Colorado 80202 Phone: 720.946.0969		IBI GROUP 1401 17th Street, Suite 610 Denver, CO 80202 303-713-1013 Fax: 303-713-1014		ORIGINAL SCALE HORIZ: 1"=1'-0" VERT:

65% SUBMITTAL	 WEST REGIONAL TRANSPORTATION DISTRICT 1560 BROADWAY #700 DENVER, COLORADO 80202 (303) 299-6990	WEST CORRIDOR	DRAWING FILE NAME: WCSTDTJ004
		TYPICAL DETAIL BIKE LOCKER AND BIKE RACK ELEVATIONS AND DETAILS	SHEET: NO. SA-141 OF SA-141